

String Potentiometer and String Encoder Engineering Guide

S054B



SpaceAge Control, Inc.
An ISO 9001/AS9000-Compliant Company
38850 20th Street East • Palmdale, CA 93550 USA
661-273-3000 • Fax: 661-273-4240 • email@spaceagecontrol.com

String Potentiometer and String Encoder Engineering Guide

A User's Perspective

[PDF Version of this Page](#)

Table of Contents

- [Overview](#)
- [Technology Review](#)
- [Advantages of CPTs](#)
- [Things to Keep in Mind](#)
- [Conclusion](#)
- [Reference Materials](#)
- [A Word from the Sponsor](#)
- [Contact Information](#)

Overview

This engineering guide reviews the advantages and disadvantages of string potentiometers and string encoders, hereafter referred to as CPTs (cable position transducers -- see [Sidebar 1](#) below for other terms). By understanding the strengths and weaknesses of CPT technology, designers, engineers, and technicians can specify and design the best displacement measurement solution for their application.



Figure 1a - CPTs offer a sensor technology that can be fitted to the application instead of fitting the application to the sensor.

Technology Review

If you are not familiar with CPTs, review the last paragraph of [Sidebar 1](#) and the accompanying Figure 1 below. CPTs were first developed in the mid-1960s in concert with the growth of the aerospace and aircraft industries. The first applications involved the monitoring of aircraft flight control mechanisms during flight testing.

While the technology is proven and mature, it is certainly not dated. A broad range of high-performance and as cost-conscious applications use CPTs as the basis for key control and monitoring operations. Recent examples include:

- Delta IV missile thrust vectoring system
- Military fighter level sensor
- Diesel engine fuel index measurement

- International Space Station environmental control systems
- commercial and military aircraft flight data recorder input sensors
- excavator hydraulic cylinder control
- medical table actuation feedback system
- V-22 flight control surface monitoring
- Global Hawk UAV landing gear stroke measurement
- logistics sorting and positioning equipment
- earth borer positioner

Sidebar 1

What's In A Name?

Never heard of a string potentiometer or string encoder? Possibly you have heard of these names:

- cable actuated position sensor
- cable extension transducer
- cable position transducer
- cable sensor
- cable-actuated sensor
- CET
- CPT
- stringpot
- string potentiometer
- draw wire encoder
- draw wire transducer
- wire rope transducer
- wire sensor
- wire-actuated transducer
- yo yo pot
- yoyo potentiometer

These names all refer to devices that measure displacement via a flexible displacement cable that extracts from and retracts to a spring-loaded drum. This drum is attached to a rotary sensor (see Figure 1).

We refer to our displacement measurement products by the generic term of "position transducer." However, we'll answer your questions no matter what YOU call them!

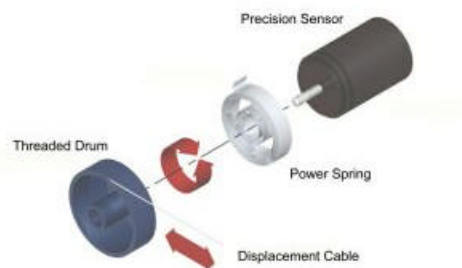

Figure 1 - How they work

Advantages of CPTs

Let's get down to business: what are the benefits of CPTs?

MULTI-AXIS CAPABILITY - As Figure 2a below shows, CPTs can be used to track linear, rotary, 2-dimensional, and 3-dimensional displacements. This capability makes CPTs ideal in test engineering as well as in OEM applications where size and mounting restrictions eliminate other choices.

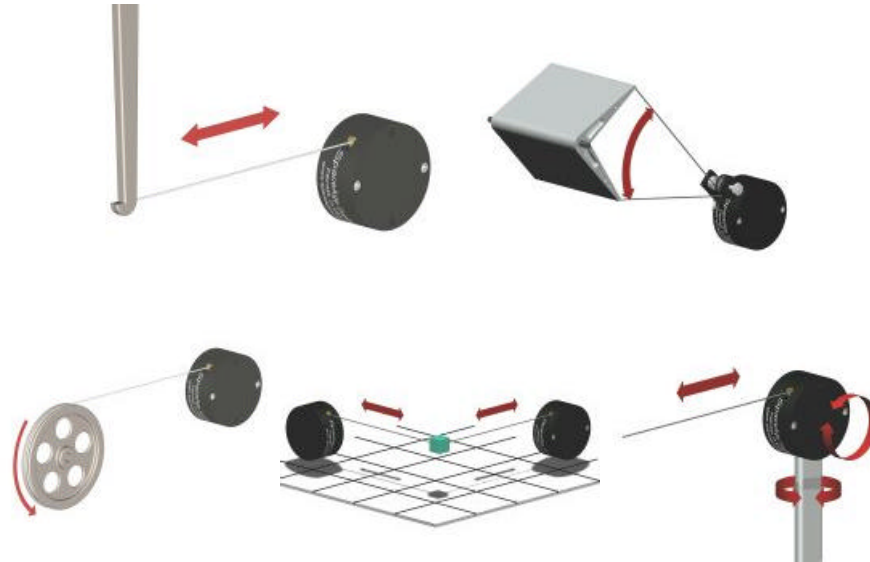

Figure 2a - Linear, angular, rotary, 2D, and 3D displacements can be monitored with CPTs.

FLEXIBLE MOUNTING - The flexible displacement cable inherent in CPT technology allows for flexible mounting. The cable can be attached to the application in a number of ways as shown in Figure 2. Other methods include magnets and eyebolts or other threaded fasteners.



Figure 2 - A few displacement cable terminations

The cable can also be routed around barriers using pulleys (see Figure 3) and flexible conduits.



Figure 3 - Pulleys and idlers allow displacement cable to be routed to the application

Finally, innovative transducer mounting bases and cable exit options (see Figures 4 and 5) give additional mounting flexibility, eliminating the expense associated with special fixturing and adapters.

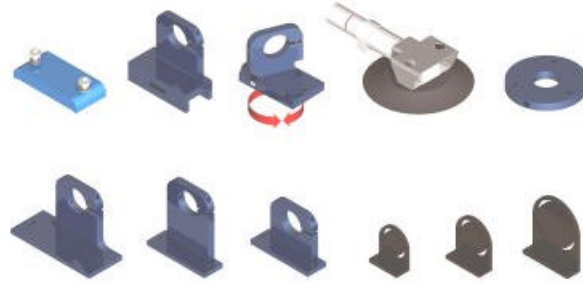

Figure 4 - A few mounting base options

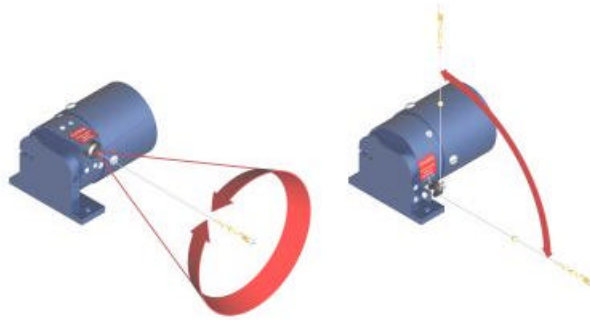

Figure 5 - Cable exit choices provide ease of installation and application flexibility

FAST INSTALLATION - The flexible mounting features combined with the broad tolerance for displacement cable misalignment provide for fast installation, often in less than 2 minutes (see Figure 6). This reduces installation costs and can be particularly valuable in test and R&D applications.



Figure 6 - Installation is quick and painless

SMALL SIZE - CPT technology gives the user a small size relative to measurement range. The world's smallest CPT measures a 1.5 inches (38.1 mm) displacement with a size of only 0.75 inch square by 0.38 inch (19 mm x 19 mm x 10 mm) as shown in Figure 7. As the measurement range increases, the CPT's relative small size advantage becomes more obvious as shown in Figure 8 below.

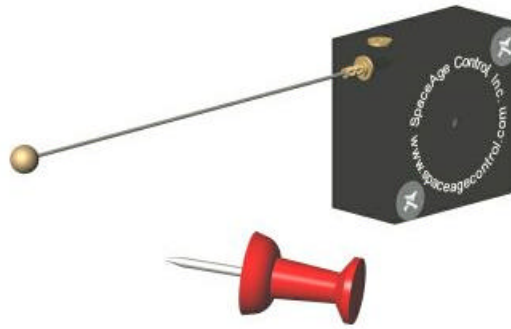

Figure 7 - World's Smallest CPT: The Series 150

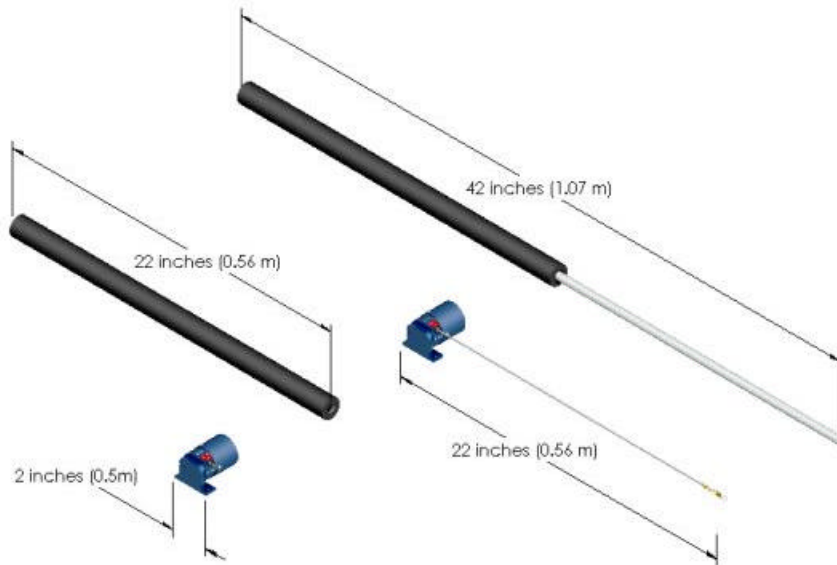

Figure 8 - Size comparison of CPTs to rod-and-cylinder devices such as LVDTs and linear potentiometers

LIGHTWEIGHT - CPTs measure displacement with a reliable, low mass stainless steel or high-strength fabric-based cable. This feature along with generally anodized aluminum components results in a product that has a low-weight-to-range ratio. This benefit can be important in space, missile, aircraft, racing, robotic, and biomedical applications. Low mass can also increase survivability in

high shock and vibration environments encountered in industrial machinery and equipment applications. Table 1 shows a comparison of weight to range for various displacement measurement sensors.

Table 1 - CPTs have a weight-to-range advantage over other sensor types
(mass shown in oz (g))

Range (in (mm))	CPT	LVDT	linear encoder	magnetostrictive
2 (51)	1 (28)	13 (369)	20 (567)	15 (425)
10 (254)	2 (57)	41 (1162)	25 (709)	29 (822)
40 (1016)	8 (227)	67 (1900)	44 (1247)	51 (1446)

RUGGED - Properly designed and manufactured CPTs have performed reliably for over 30 years in harsh industrial, aerospace, testing, and outdoor environments. The design of CPTs can be mechanically and electrically simple, resulting in high reliability, low maintenance, and years of service. CPT environmental testing has been conducted (see <http://spaceagecontrol.com/newsd0160d.htm>) demonstrating the effective operation of CPTs in environments containing high shock, vibration, humidity, corrosion, moisture, and other parameters.

VARIETY OF ELECTRICAL OUTPUTS - What does your controller or data acquisition device require? 4-20 mA? 0 to 5 VDC? 0 to 10 VDC? ± 5 VDC? ± 10 VDC? Strain gage compatible? Quadrature? RS-232? LVDT or RVDT type signals? Synchro or resolver type signals? Because CPTs can incorporate a broad range of rotary sensors and related signal conditioning, the electrical output of your choice is typically available.

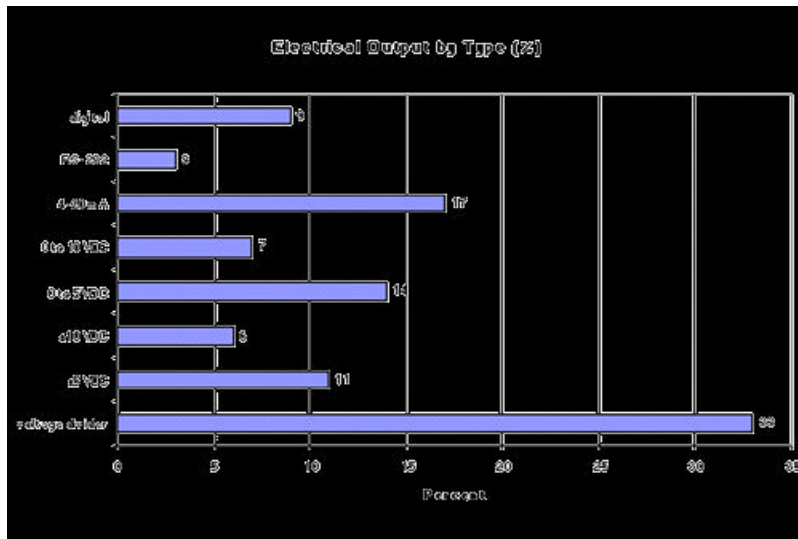

Figure 9 - Typical Electrical Output by Frequency of Use

LOW POWER, SIMPLE SIGNAL CONDITIONING - CPTs, particularly analog potentiometer types, generally have low power and simple signal conditioning requirements. 5 VDC power or less is suitable and no special signal conditioning is required for the majority of applications. The CPT signal input and output requirements can reduce total system cost, allow for fast setup, and allows for relatively inexperienced personnel to work with the devices.

UNOBTRUSIVE - The small size and low mass of CPTs give them a small profile. This provides for aesthetically pleasing designs. Additionally, this unobtrusiveness reduces the possibility for unwanted application interaction (accidental interference) with the transducer. Finally, the displacement cable can be designed to "break away" in applications where it is paramount that sensor failure does not interfere with the measured object. This can be quite important in flight control applications where flight safety can be affected if a failure of sensor's actuation mechanism makes it impossible for the aircraft to be properly controlled.

BROAD OPERATING TEMPERATURE - Analog-output CPTs can operate in temperate ranges from -65° to +125° C while digital-output CPTs can range from -40° to +85° or -20° to +100° C. This broad operating range reduces operating and installation issues and makes the products well-suited for outdoor, aerospace, and industrial control applications. Broader operating ranges can be attained with the use of custom sensors.

ACCURACY - Using non-backlash connections and threaded drums, analog-output CPTs can offer linearity-compensated accuracy exceeding $\pm 0.025\%$ of full scale. As an example, a 10-inch (254-mm) range analog-output CPT can give an accuracy of ± 0.0025 inch (± 0.0635 mm).

BROAD MEASUREMENT RANGE - CPTs measurement ranges are broad: 1.5 inches to over 2000 inches (38 mm to over 50 m). For some long-range measurement challenges, the CPT is the only feasible solution.

COST EFFECTIVE - CPTs are generally cost-effective devices, especially when considering lifetime costs. Typical prices range from \$100.00 to \$1000.00. Flexible mounting, fast installation, high reliability, and minimal signal conditioning requirements reduce costs relative to many alternatives. The CPT's cost effectiveness increases at longer ranges because the displacement cable is the primary cost adder to the design in going from shorter ranges to longer ranges.

Things to Keep in Mind

There is no perfect sensing technology. CPTs are no exception. Even Superman has his Kryptonite. When considering a CPT for your application, keep the following items in mind.

FREQUENCY RESPONSE - CPTs are used extensively in vehicle impact testing where accelerations exceed 50 g's. CPTs have been used in other applications where accelerations approach 100 g's. However, applications involving extreme acceleration can exceed the frequency response capabilities of CPTs. Examples where CPT frequency response can be an issue include applications that require cable accelerations in excess of 100 g's and environments using analog-output CPTs with very high frequency, low displacement motion that tends to cause dithering wear of the potentiometric element. During extreme high accelerations, it is possible the cable reel's inertia and the power spring's insufficient torque will cause the reel to rotate to a point where the displacement cable goes slack.

LIFETIME - CPTs with optical encoder or conductive plastic sensing technologies can operate in excess of 100 million shaft revolutions. However, longer range analog-output CPTs require multi-turn potentiometers with lifetimes of less than 10 million shaft revolutions. While long-displacement, high-cycle applications are not common, you should do a thorough cost and reliability analysis before specifying a CPT for this type of use.

CABLE TENSION ON APPLICATION - Non-contact sensing devices such as ultrasonic, Hall effect, or laser do not mechanically affect the application. The CPT's cable tension imparts a load on the application. While this load can be minimized to as little as 1 oz. (0.278 N), it cannot be eliminated. Hence, for applications sensitive to external loads, other technologies should be considered.

CABLE INTERFERENCE - The CPT's small, lightweight displacement cable is one of its key advantages. In some applications, it can be a disadvantage. For example, inadvertent damage can occur if technicians and operators do not know of the cable's presence. While signage and protective tubing or other devices can be installed, damage can still occur from unplanned events.

ACCURACY - CPTs that use no-backlash mechanical connections and threaded drums deliver excellent accuracy. Nevertheless, this is sometimes insufficient for some applications. For those situations, you should consider using LVDTs, laser-based devices, or other higher-accuracy technologies.

Accuracy is a broadly-used yet not always fully-defined word. When you are determining what "accuracy" you require for your application, ensure you really need the accuracy you are specifying. Otherwise, you may be paying for a lot of capability that will go unused. See if your application does not require raw accuracy but rather good linearity, resolution, repeatability, or hysteresis.

CATENARY CURVE ERROR EFFECTS - A catenary curve describes the shape the displacement cable takes when subjected to a uniform force such as gravity. Because the mass of the cable per unit length is so small and the cable tension is relatively high, cable sag does not produce any significant error unless the cable length is exceptionally long (over 60 feet (18 meters)). The cable sag error is minor compared to other error sources (generally less than $\pm 0.0025\%$). Nevertheless, some applications (typically involving high angular rotation or long measurements) produce sufficient forces to cause significant cable sag error. To calculate the catenary curve error effect for your application, visit <http://spaceagecontrol.com/calccabl.htm>.

Conclusion

Cable position transducers can be flexible, robust, cost-effective displacement measurement devices for a broad range of applications. At the same time, these products have limitations that may result in other technologies being more appropriate for specific applications.

Reference Materials

These documents provide additional information on the selection and use of CPTs:

- [Application Note for Aircraft/Aerospace \(S004A\)](http://spaceagecontrol.com/s004a.pdf)
<http://spaceagecontrol.com/s004a.pdf>
- [Application Note for Ground Vehicles/Transportation \(S005A\)](#)

<http://spaceagecontrol.com/s005a.pdf>

- [Selecting Position Transducers](#)

<http://spaceagecontrol.com/selpt.htm>

A Word from the Sponsor

SpaceAge Control is the only company in the world focused exclusively on robust string potentiometers and string encoders. We invented the miniature string potentiometer in 1968. We have been perfecting it ever since.

This has been our business for almost 35 years. We have the design skills, application knowledge, and quality system to meet your requirements on time, on budget, and with your complete satisfaction. To evaluate these products for your application at no risk, consider the [Evaluation Transducer Program](http://www.spaceagecontrol.com/reqevalpt.htm).

Some high-profile and unique products, applications, and features include:

A Few SpaceAge Control Highlights

first CPT aboard the International Space Station and the virtual standard for space-based applications

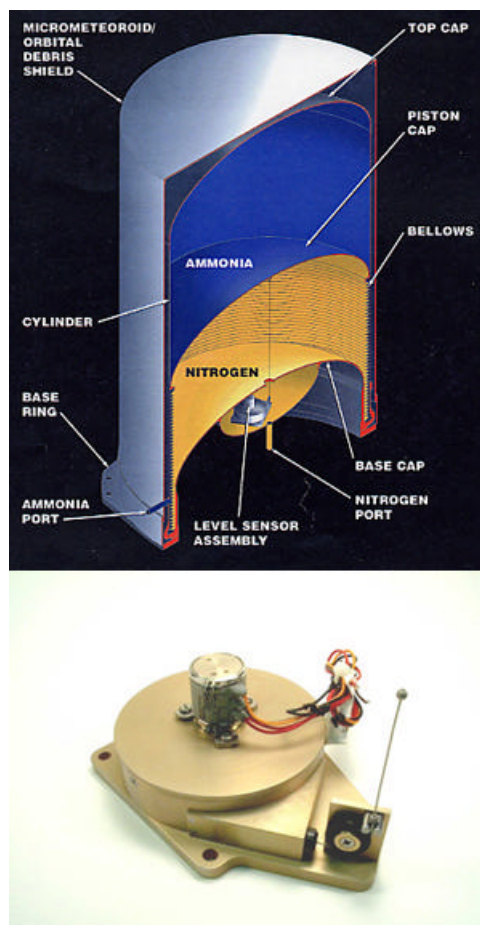

Figure 10 - SpaceAge Control position transducers for man-rated space vehicles assist in the control of life-critical environmental control systems.

only CPT qualified for crash test dummies (knee, chest, ribcage, and abdomen)



Figure 11 - Crash test dummies get smart with SpaceAge Control position transducers

CPT standard for Formula 1, IRL, CART, and NASCAR racing

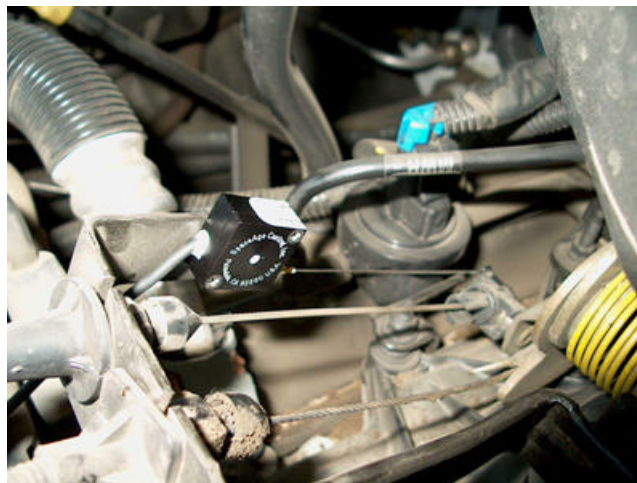

Figure 12 - NASCAR, IRL, CART, and Formula 1 vehicles push the limits of technology with SpaceAge Control displacement sensors

displacement sensor of choice for flight data recorder upgrades

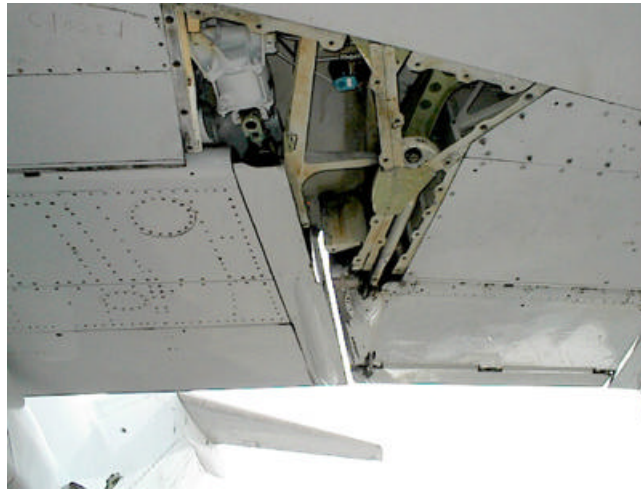

Figure 13 - Airlines and militaries across the world rely on SpaceAge Control position transducers to reliably obtain data

only CPT fully qualified to DO-160D / ED-14D and MIL-STD-810E

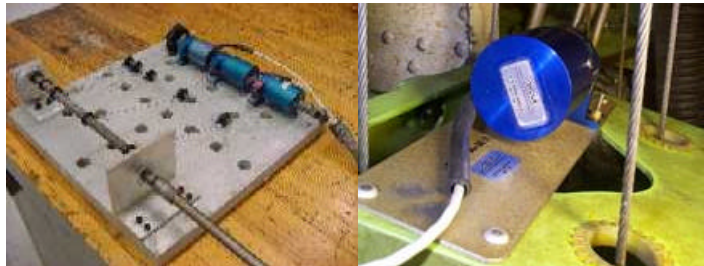

Figure 14 - DO-160D test fixture and on-aircraft installed sensor

pioneered the use of the non-g geared, non-clutched, servo-mount sensor that allows easy zeroing and ensures no backlash (DirectConnect(tm) technology)

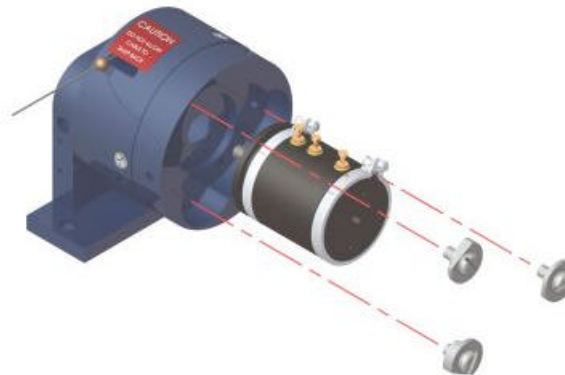
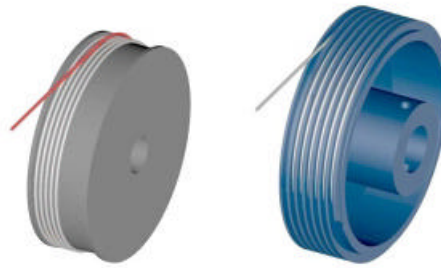

Figure 15 - DirectConnect(tm) technology is emulated worldwide today.

only manufacturer of AccuTrak(tm)
CPTs that virtually eliminate non-
repeatability from cable side-to-side
and overlap motion



Non-Threaded Drum

Threaded Drum

Figure 16 - AccuTrak(tm) threaded drums (right) give superior repeatability as compared to non-threaded drums.

developed patent on universal
mounting base offering 360° of
rotation about 2 axes for unparallelled
mounting flexibility



Figure 17 - The universal base, patented in 1974, provides unparallelled mounting flexibility and ease of use with 360° rotation in two axes.

Contact Information

SpaceAge Control, Inc.
38850 20th Street East - Palmdale, CA 93550 USA
661-273-3000 - 661-273-4240 (fax)
email@spaceagecontrol.com - <http://spaceagecontrol.com/>